

PRODUCT CONFIGURATION

MX-C303W MX-C304W

Base models include 7-inch touch screen, wireless connectivity, multitasking controller, 500 GB HDD with document filing system, PCL®6 and Adobe® PostScript® 3™ networking printing systems, network scanning, fax, 250-sheet paper drawer and 50-sheet multi-bypass tray. The MX-C303W includes a 50-sheet reversing single pass feeder (RSPF), OSA optional. The MX-C304W includes a 100-sheet duplex single pass feeder (DSPF). Starter toner included.

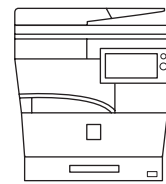

MX-C303W

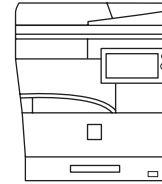

MX-C304W

Multifunctional Digital Document Systems – 250 Sheet Single Tray (included)

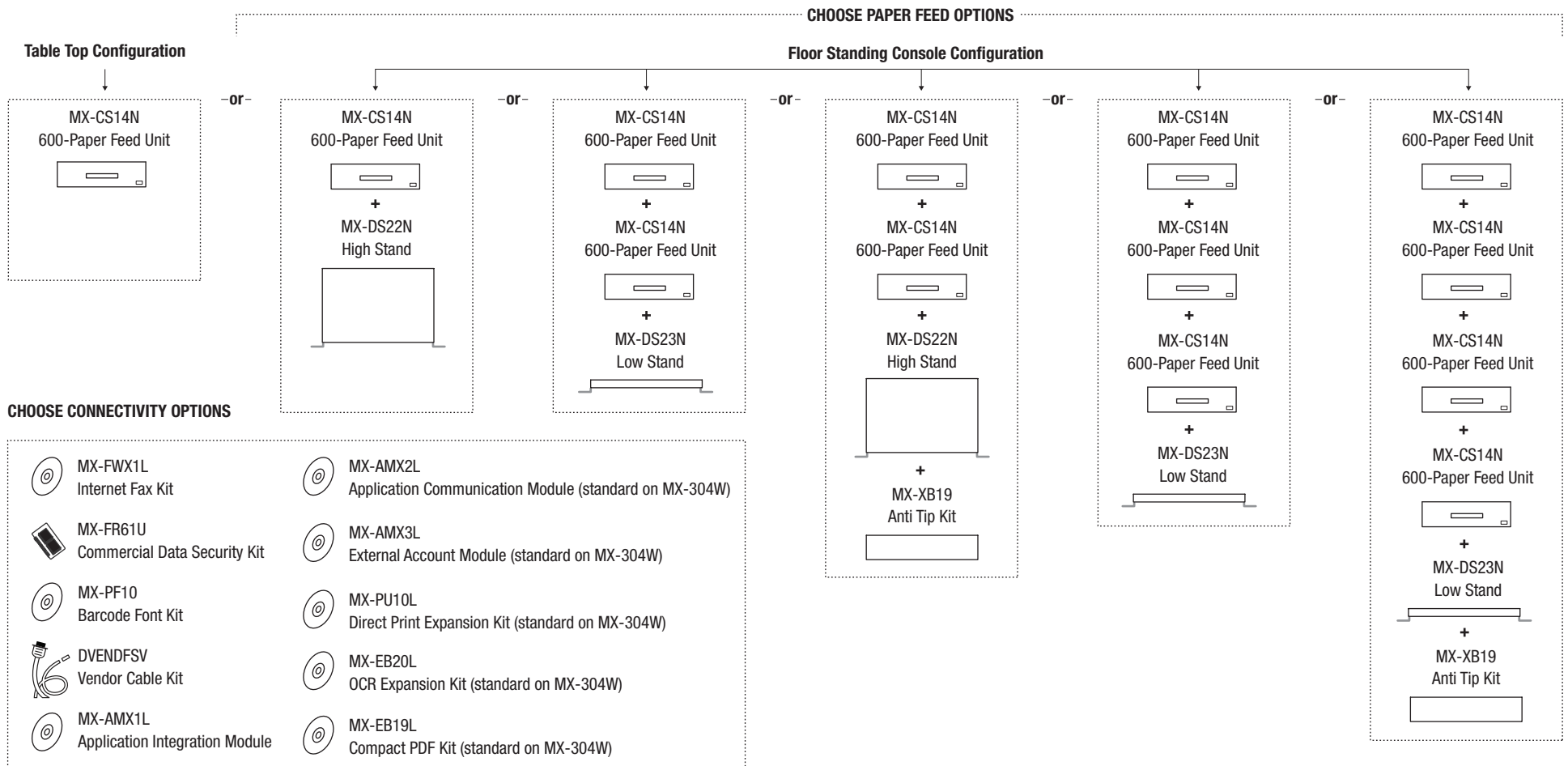

SPACE REQUIREMENTS AND PLANNING

MX-C304W
(standard drawer table top)
300-sheet maximum

MX-C304W + MX-CS14N
(1 additional drawer table top)
900-sheet maximum

MX-C304W + MX-CS14N + MX-DS22N
(standard drawer floor standing)
900-sheet maximum

MX-C304W + (2) MX-CS14N + MX-DS23N
(2 additional drawers floor standing)
1,500-sheet maximum

MX-C304W + (3) MX-CS14N + MX-DS23N
(3 additional drawers floor standing)
2,100-sheet maximum

MX-C304W + (4) MX-CS14N + MX-DS23N
(4 additional drawers floor standing)
2,700-sheet maximum

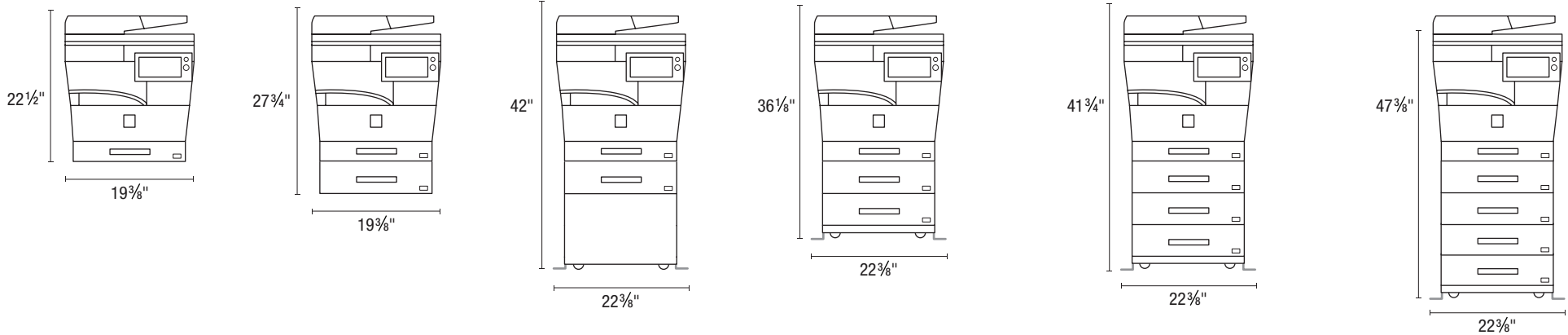

Note: MX-C304W shown. Configurations are 2 inches shorter with MX-C303W.

Main Unit

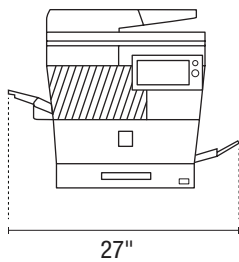

Overhead View with Stand

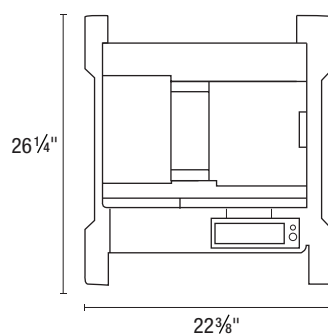

Design and specifications are subject to change without notice. All product dimensions listed are approximate.

Plan ahead to ensure your installation is a great success! Check the latest information on these products and have the following items available prior to installation.

- **Firmware:** Check the Sharp-PC Service site to make sure the machine and accessories have the latest firmware prior to installation at the customer site.
- **Power Source:** Verify the power source at the customer site: MX-303W/C304W requires 120 V AC @ 60 HZ with a 12 A receptacle outlet and circuit breaker.
- **Product Keys:** Obtain application codes for any accessories that may require a product key prior to arrival at the customer site.
- **Supplies:** Verify that the customer has enough supplies on hand. Starter toner included.

MX-C30NTB	Black Toner Cartridge	MX-C32NVB	Black Developer
MX-C30NTC	Cyan Toner Cartridge	MX-C32NVC	Cyan Developer
MX-C30NTM	Magenta Toner Cartridge	MX-C32NVM	Magenta Developer
MX-C30NTY	Yellow Toner Cartridge	MX-C32NVY	Yellow Developer
		MX-C30DR	Drum

Check to see if My Sharp™ online training is set up for the end-user.

