

PRODUCT CONFIGURATION & SPACE REQUIREMENTS

Product Configuration

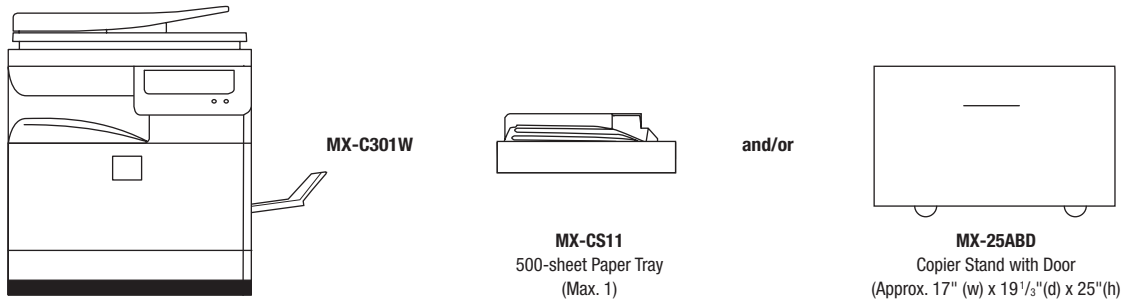

Space Requirements and Planning Guide

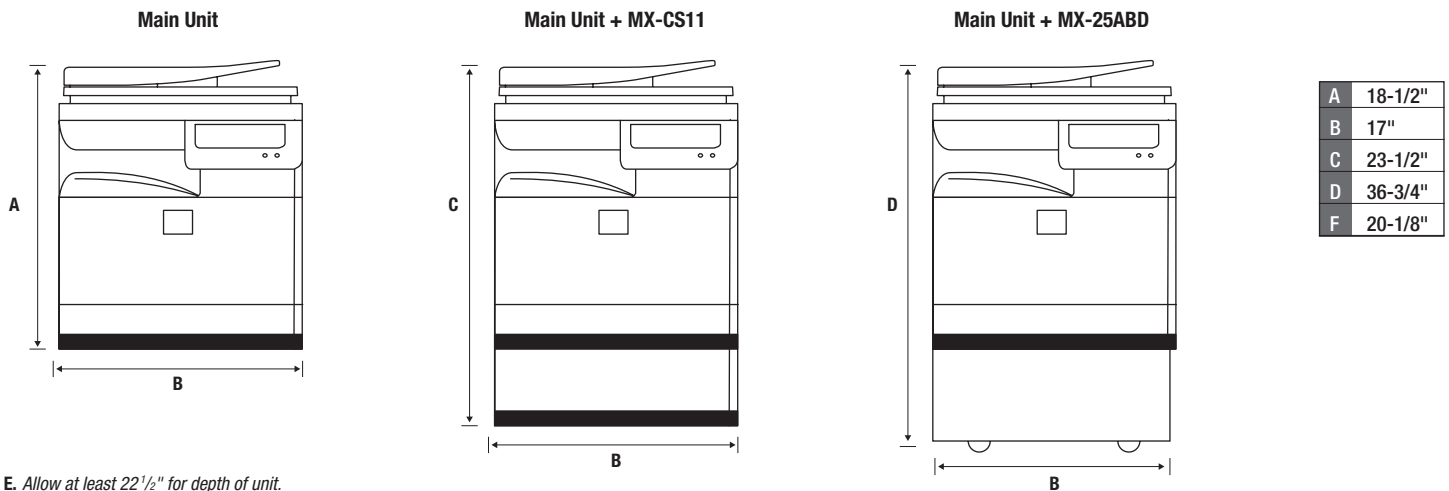

Read this document in its entirety before planning your configuration.

Plan ahead and make sure your installation is a great success! Remember to check the latest information on these products and make sure that the following items are available prior to installation.

- Verify power dedication and check for power stability. The MX-C301W Document System requires AC 120V, 60 Hz power source, 9 Amps power source.
- Confirm that you have the latest firmware available to upgrade your MX-C301W Document System immediately.
- Make sure the customer has enough supplies on-hand to complete a large rush job. After-hours printing and/or holiday work may take place following an installation.

MX-C30NTB Black Toner Cartridge
 MX-C30NTC Cyan Toner Cartridge
 MX-C30NTM Magenta Toner Cartridge
 MX-C30NTY Yellow Toner Cartridge

- Check to see if My Sharp™ online training is set up for the end-user

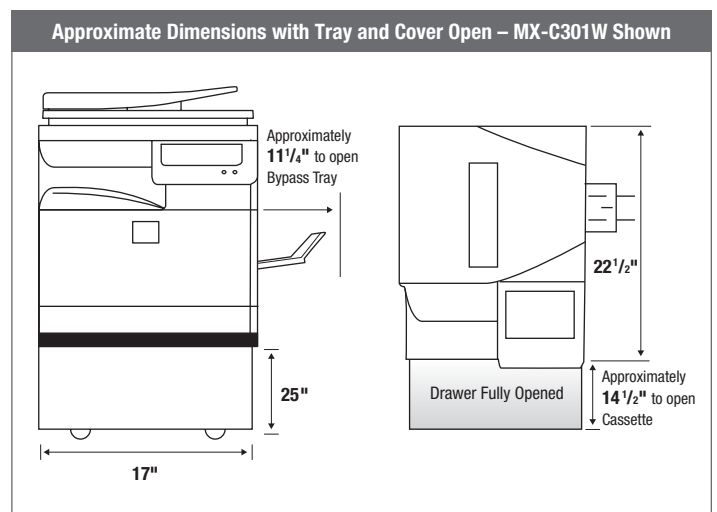

For complete installation procedures please contact your authorized Sharp servicing dealer. Design and specifications are subject to change without notice. All product dimensions listed are approximate. Sharp and My Sharp are trademarks or registered trademarks of Sharp Corporation and/or affiliated companies. All other trademarks are the property of their respective owners.