

PRODUCT CONFIGURATION

MX-M3050/M3550/M4050/M5050/M6050

Base models include quad-core multitasking controller, 500 GB hard disk drive with document filing system, PCL®6 printing system, network printing, network scanning, 100-sheet reversing single-pass feeder, auto duplexing, 550-sheet paper drawer and 100-sheet bypass tray. Standard Security with End-of-Lease feature.

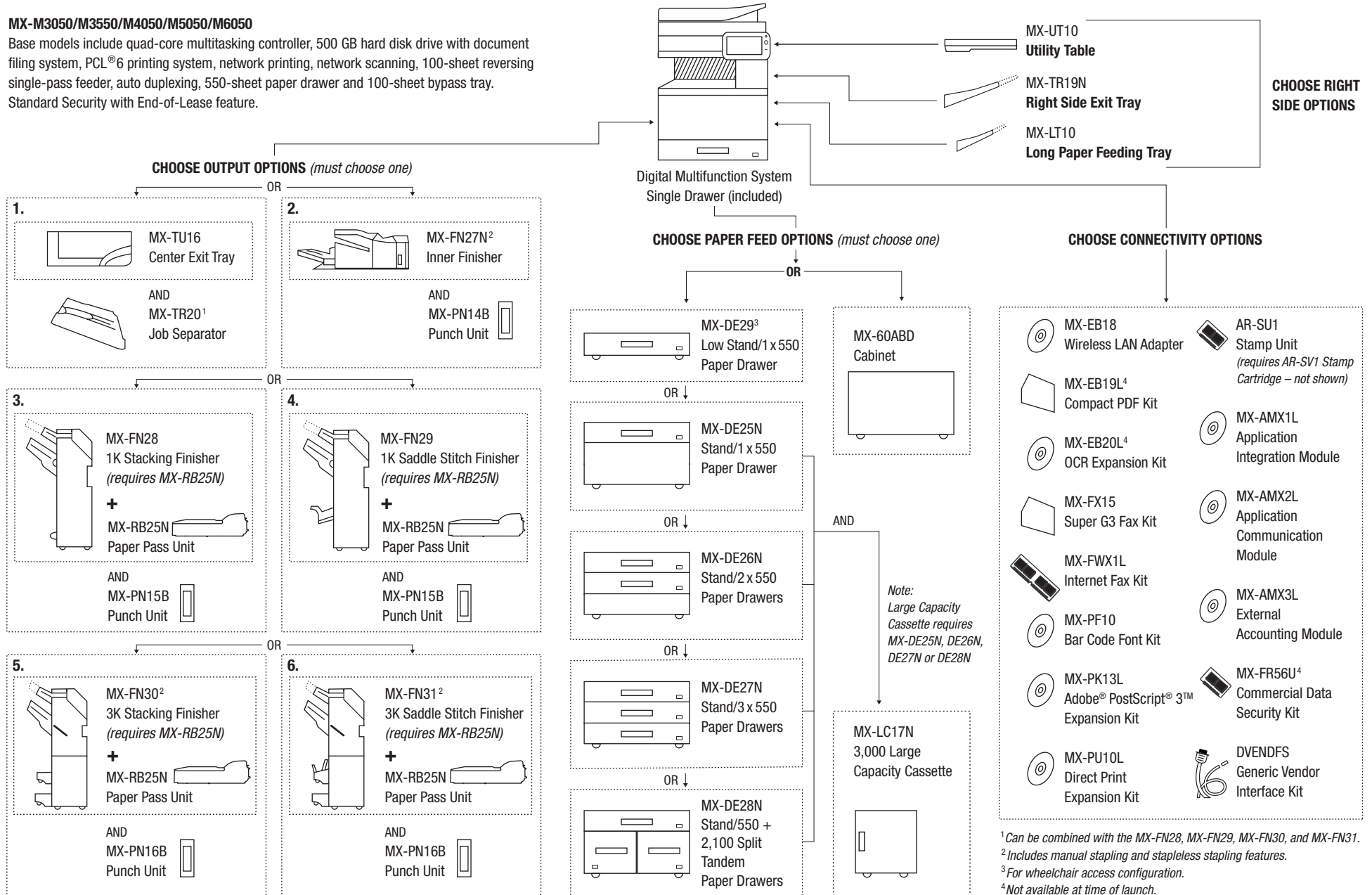

¹ Can be combined with the MX-FN28, MX-FN29, MX-FN30, and MX-FN31.

² Includes manual stapling and stapleless stapling features.

³ For wheelchair access configuration.

⁴ Not available at time of launch.

SPACE REQUIREMENTS AND PLANNING

Main Unit + MX-TU16 + MX-60ABD
(standard drawer plus cabinet)
650-sheet maximum

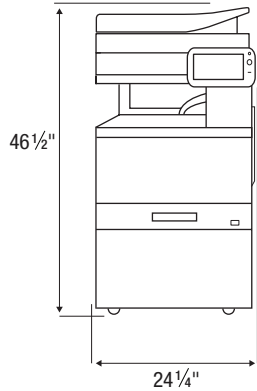

Main Unit + MX-TU16 + MX-DE25N
(1 additional drawer)
1,200-sheet maximum

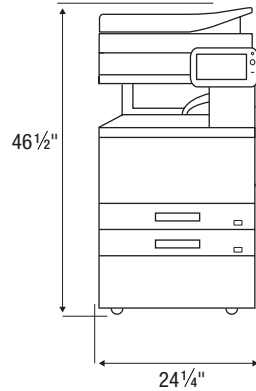

Main Unit + MX-TU16 + MX-DE26N
(2 additional drawers)
1,750-sheet maximum

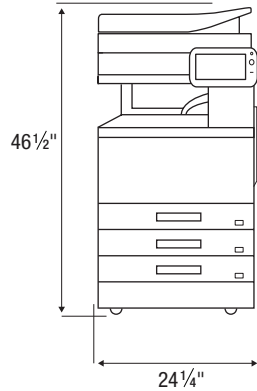

Main Unit + MX-TU16 + MX-DE27N
(3 additional drawers)
2,300-sheet maximum

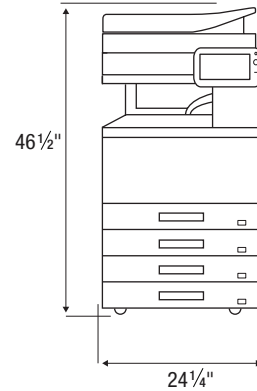

Main Unit + MX-TU16 + MX-DE28N
(1 additional drawer + 2 split tandem drawers)
3,300-sheet maximum

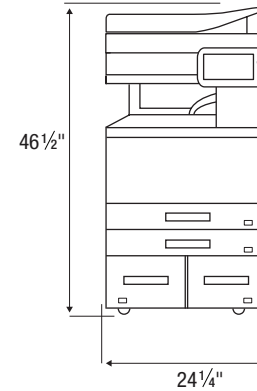

Main Unit + MX-TU16 + MX-DE29
(1 additional drawer –
for wheelchair access)
1,200-sheet maximum

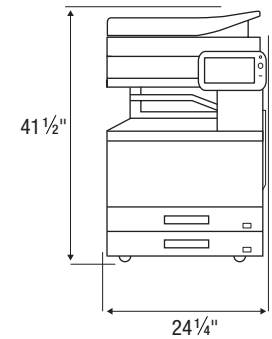

1 Main Unit + MX-TU16 + MX-DE27N + MX-LC17N (5,300-sheet maximum)

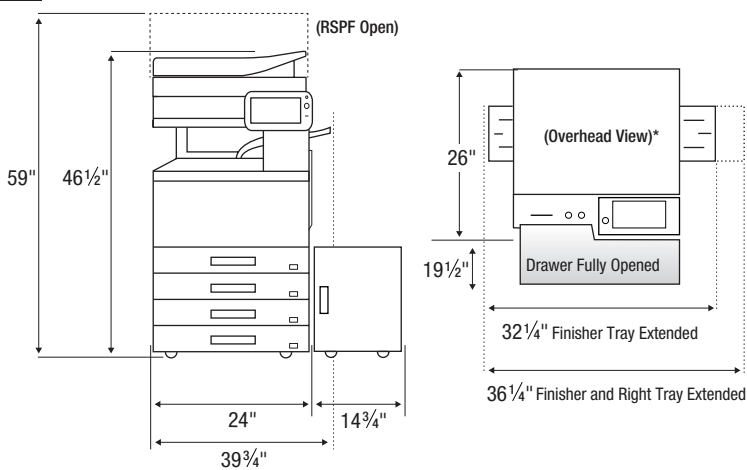

2 Main Unit + MX-RB25N + MX-FN29 + MX-DE28N + MX-LC17N (6,300-sheet maximum)

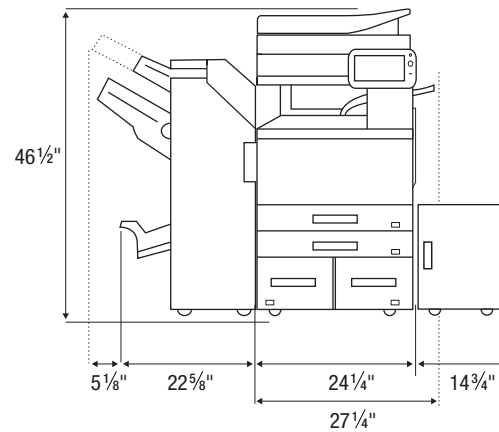

*Other finishers include the MX-FN28, MX-FN30 and MX-FN31.

Plan ahead to ensure your installation is a great success!

- Firmware:** Check the Sharp-PC Service site to make sure the machine and accessories have the latest firmware prior to installation at the customer site.
- Power Source:** Verify the power source at the customer site. The MX-M3050/M3550/M4050/M5050/M6050 requires 110-127 V AC @ 60 HZ with a 15 A receptacle outlet and circuit breaker.
- Product Keys:** Obtain application codes for any accessories that may require a product key prior to arrival at the customer site.
- Supplies:** Verify that the customer has enough supplies on hand.

MX-561NT Toner

MX-560DR Drum

MX-561NV Developer

MX-609HB Toner Collection Container

 Check to see if My Sharp™ online training is set up for the end-user.

SHARP

Design and specifications are subject to change without notice. All product dimensions listed are approximate.