

## PRODUCT CONFIGURATION

### MX-M2630

Base model includes quad-core multitasking controller, 500 GB hard disk drive with document filing system, PCL®6 printing system, network printing, network scanning, 100-sheet reversing single-pass feeder, standard center exit tray, auto duplexing, 550-sheet paper drawer and 100-sheet bypass tray. Standard Security with End-of-Lease feature.

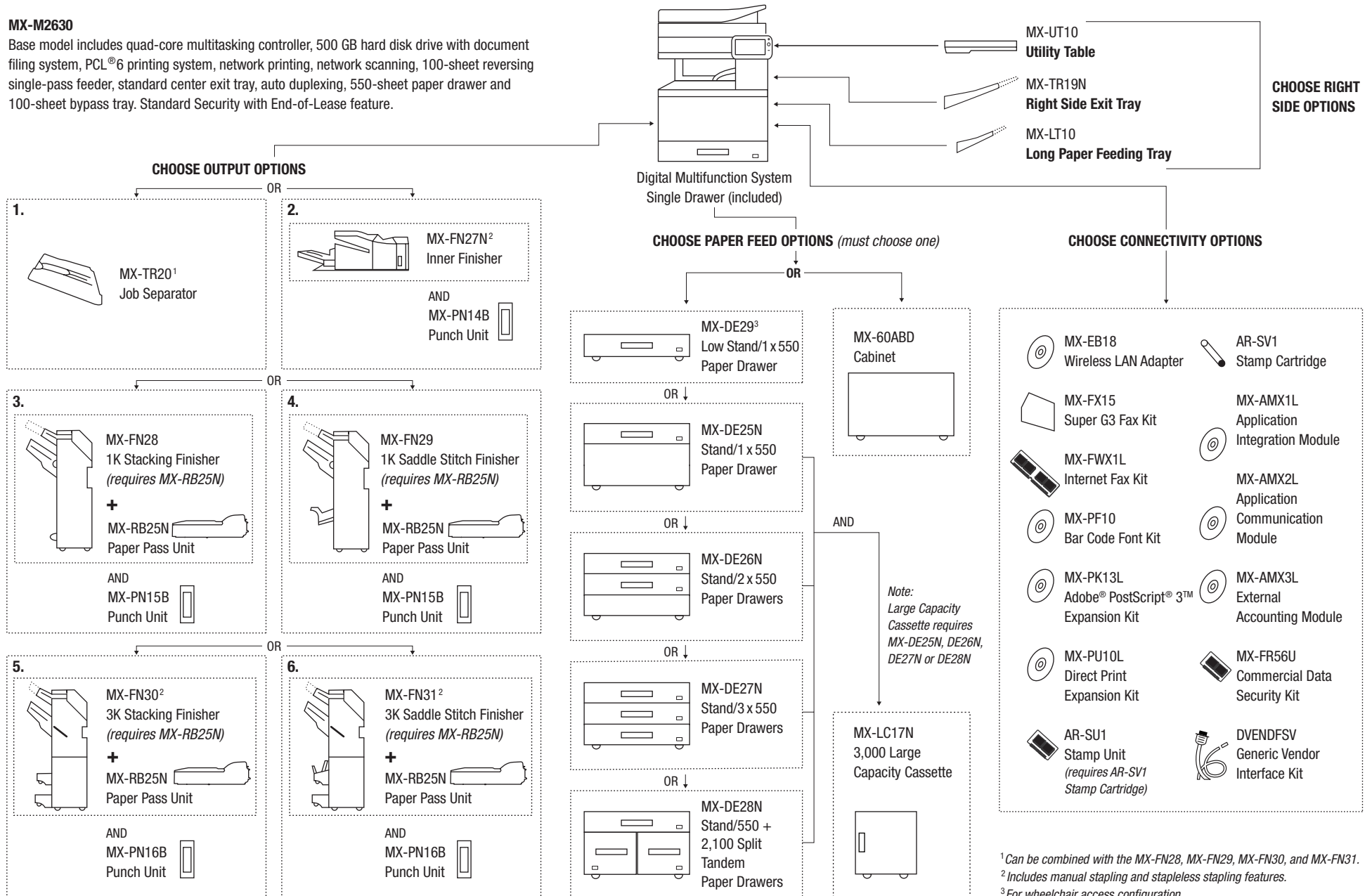

<sup>1</sup> Can be combined with the MX-FN28, MX-FN29, MX-FN30, and MX-FN31.

<sup>2</sup> Includes manual stapling and stapleless stapling features.

<sup>3</sup> For wheelchair access configuration.

## SPACE REQUIREMENTS AND PLANNING

**Main Unit + MX-60ABD**  
(standard drawer plus cabinet)  
650-sheet maximum

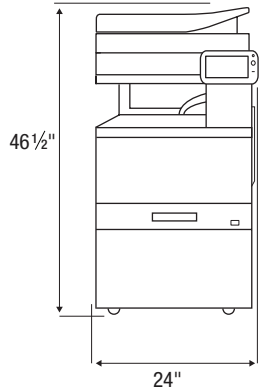

**Main Unit + MX-DE25N**  
(1 additional drawer)  
1,200-sheet maximum

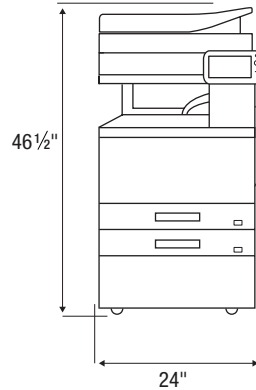

**Main Unit + MX-DE26N**  
(2 additional drawers)  
1,750-sheet maximum

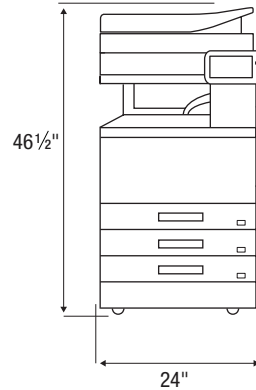

**Main Unit + MX-DE27N**  
(3 additional drawers)  
2,300-sheet maximum

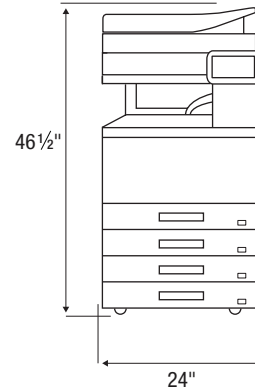

**Main Unit + MX-DE28N**  
(1 additional drawer + 2 split tandem drawers)  
3,300-sheet maximum

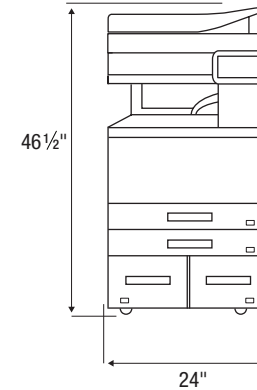

**Main Unit + MX-DE29N**  
(1 additional drawer –  
for wheelchair access)  
1,200-sheet maximum

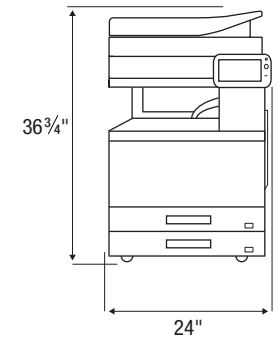

**1 Main Unit + MX-DE27N + MX-LC17N** (5,300-sheet maximum)

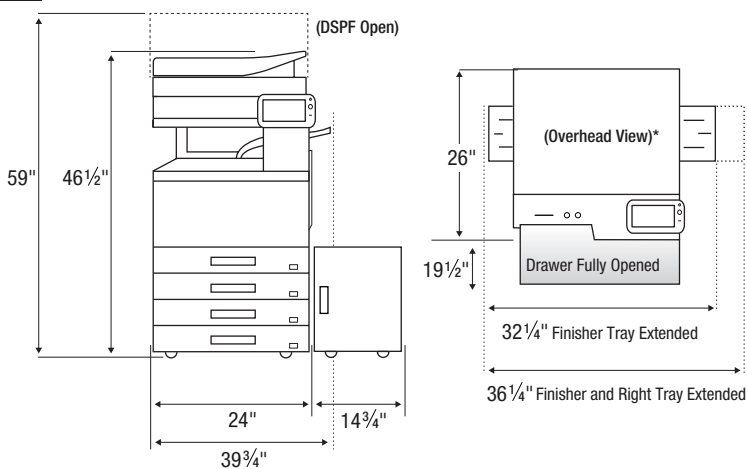

**2 Main Unit + MX-RB25N + MX-FN29 + MX-DE28N + MX-LC17N**  
(6,300-sheet maximum)

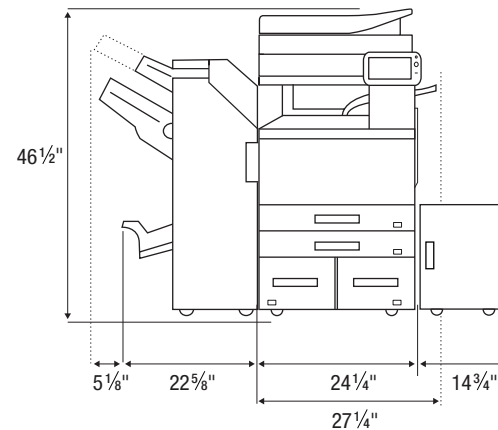

\*Other finishers include the MX-FN28, MX-FN30 and MX-FN31.

### Plan ahead to ensure your installation is a great success!

- 1. Firmware:** Check the Sharp-PC Service site to make sure the machine and accessories have the latest firmware prior to installation at the customer site.
- 2. Power Source:** Verify the power source at the customer site:  
MX-M2630: Requires 110-127 V AC @ 60 HZ with a 15 A receptacle outlet and circuit breaker.
- 3. Product Keys:** Obtain application codes for any accessories that may require a product key prior to arrival at the customer site.
- 4. Supplies:** Verify that the customer has enough supplies on hand.

**MX-561NT** Toner  
**MX-561NV** Developer  
**MX-560DR** Drum  
**MX-560HB** Toner Collection Container



Check to see if My Sharp™ online training is set up for the end-user.

Design and specifications are subject to change without notice. All product dimensions listed are approximate.