

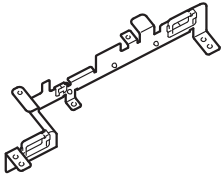





MK-P04/FK-512 Mount Kit/Fax Kit INSTALLATION MANUAL

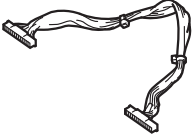
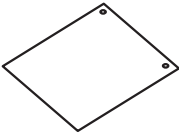

Applied Machines: C3110
 COLOR MFP: 31 ppm
 Product Code: A6DT

1. Accessory parts

< Mount kit MK-P04 >

No.	Name	Shape	Q'ty
1.	Mounting plate		1
2.	Cable A		1
3.	Cable B		1
4.	Insulation sheet		1
5.	Screw		6
6.	Super G3 label		1
7.	Installation manual		1 set

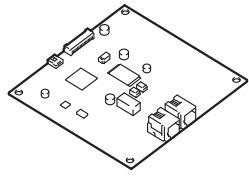
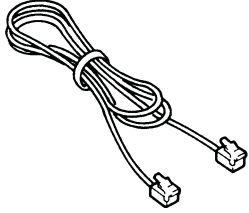
< Fax kit FK-512 >

No.	Name	Shape	Q'ty
1.	Fax board		1
2.	Modular cable		1
3.	Name plate label*		1

* Varies depending on the applicable marketing area

WARNING



Keep this bag away from babies and children. Do not use in cribs, beds, carriages, or playpens.



The thin film may cling to nose and mouth and prevent breathing. This bag is not a toy.

Note:

This manual provides the illustrations of the accessory parts and machine that may be slightly different in shape from yours. In that case, instead of the illustrations, use the appearance of your machine to follow the installation procedure. This does not cause any significant change or problem with the procedure.

2. Installation procedures

- (1) Turn OFF the power switch and unplug the power cord from the power outlet.
- (2) Open the packing carton of each option and take out the accessory parts.
- (3) Remove the rear center cover.

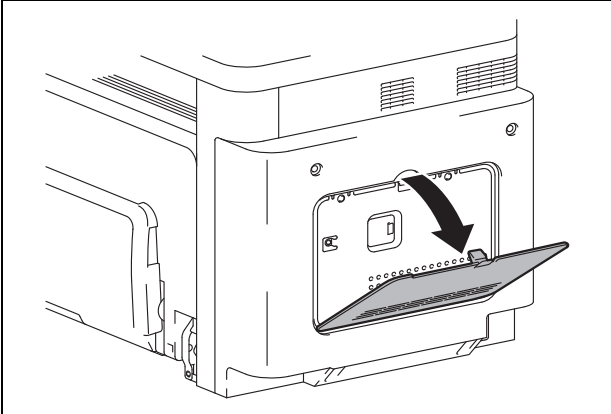

- (4) Remove the rear cover. (Six screws)

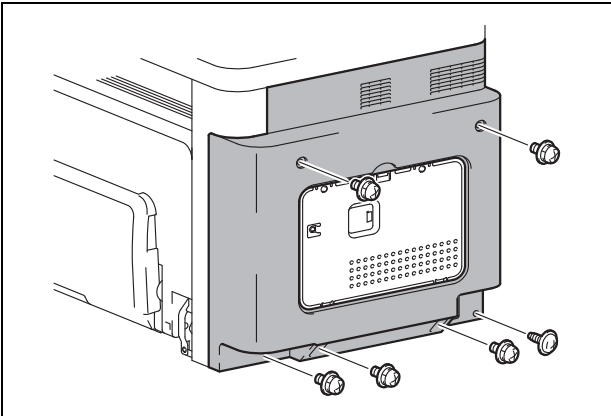

- (5) Remove the knockout from the rear cover.

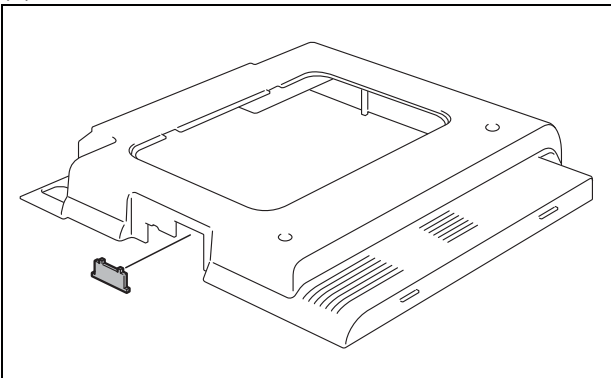

- (6) Remove the board protective shield. (14 screws)

Note:

If the optional hard disk is mounted, the cables are connected between the shield and machine (refer to step (7)). Therefore, be careful not to strongly pull the shield when removing it.

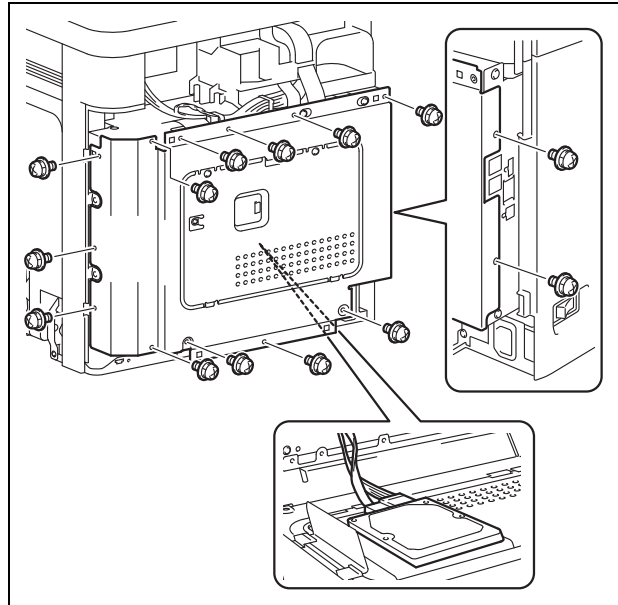

- (7)

< Only if the optional hard disk is mounted >
Disconnect the two cables on the hard disk kit from the MFP board.

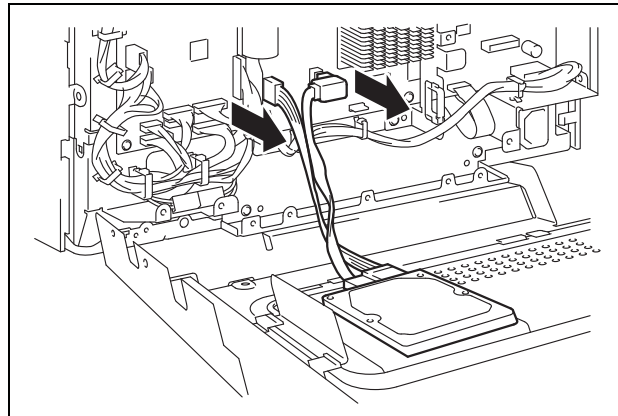

- (8) Remove the cable shown in the illustration from the wire saddle and disconnect the connector from the MFP board.

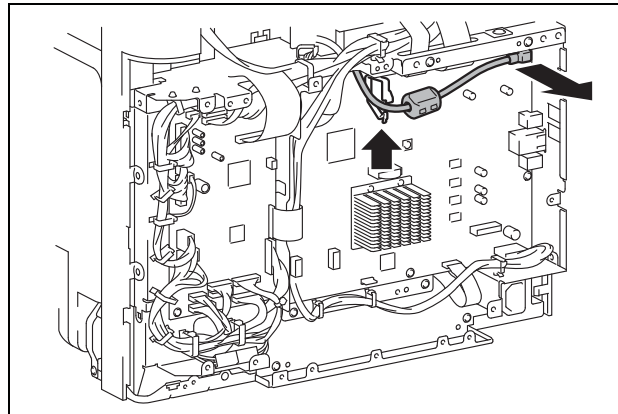

(9) Remove the screw shown in the illustration from the MFP board.

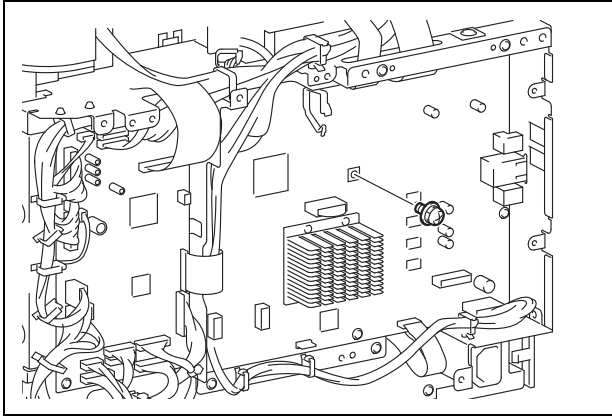

(10) Attach the supplied mounting plate.
(Two supplied screws and the screw removed in step (9))

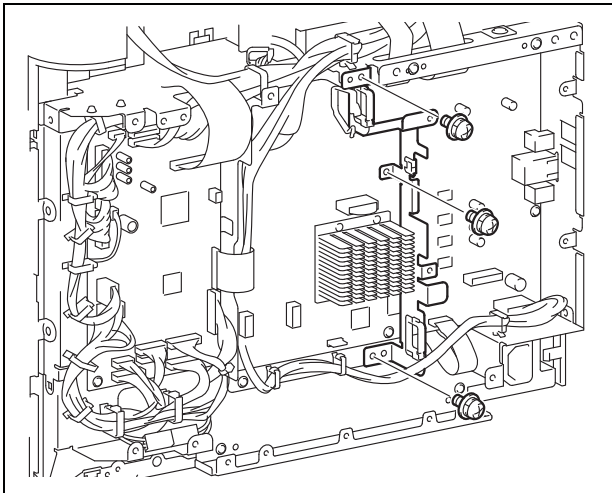

(11) Connect the supplied cables A and B to the fax board.

Note:

- Plug in the straight connector of the cable A.
- The cable B can be connected back to front.

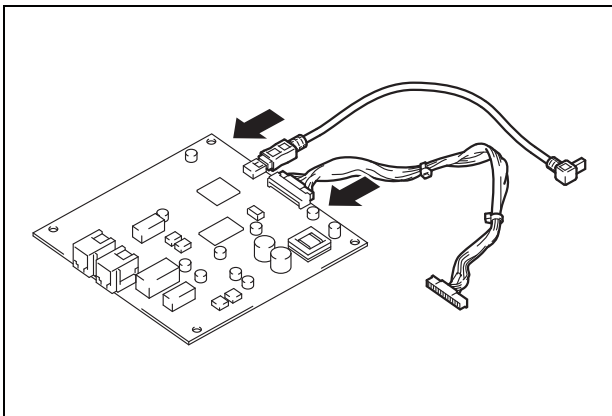

(12) Connect the cable B of the FAX board to the MFP board and route it through the three wire saddles and the edge cover.

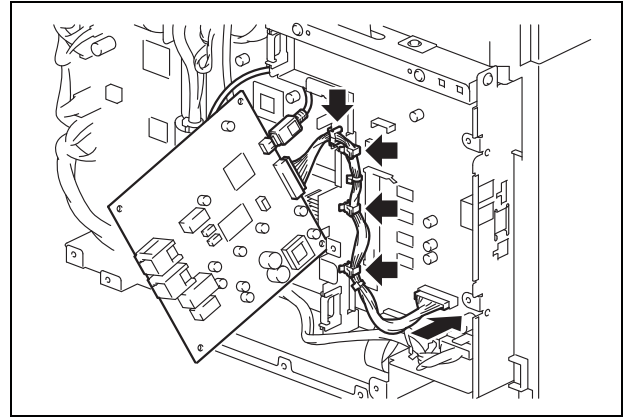

(13) Connect the fax board cable A to the MFP board connector (FAX).

(14) Connect the cable that is removed at step (8) to the MFP board connector (HOST).

(15) Route the cables and the harness through the three wire saddles.

(16) Fix the FAX board with the two supplied screws. (Two places on the right side)

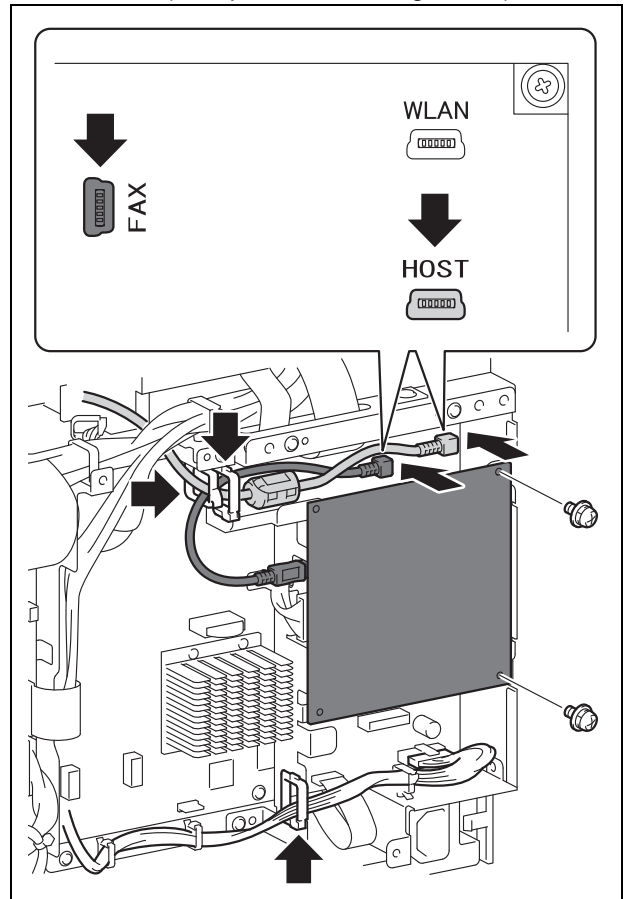

- (17) Attach the supplied insulation sheet.
(Two supplied screws)

! CAUTION

The FAX Kit contains high voltage portions.



Be sure to attach the specified insulation sheet or cover to prevent electric shock.

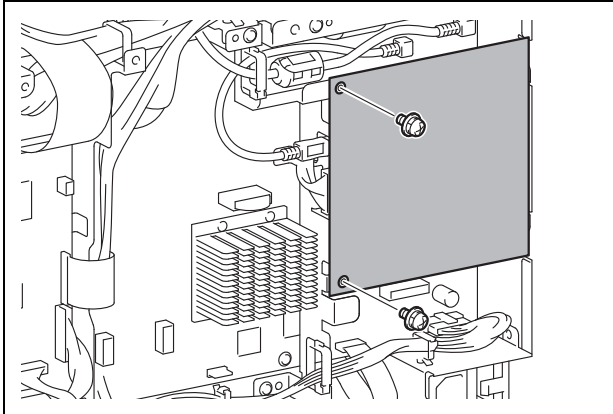

- (18)
< Only if the optional hard disk is mounted >
Connect the cables removed in step (7) to the MFP board.

- (19) Attach the board protective shield. (14 screws)

Note:

- The square holes on the board protective shield are the portions where the housing cover is screwed. Do not tighten screws at those portions.
- Tighten the screw A shown in the illustration first.

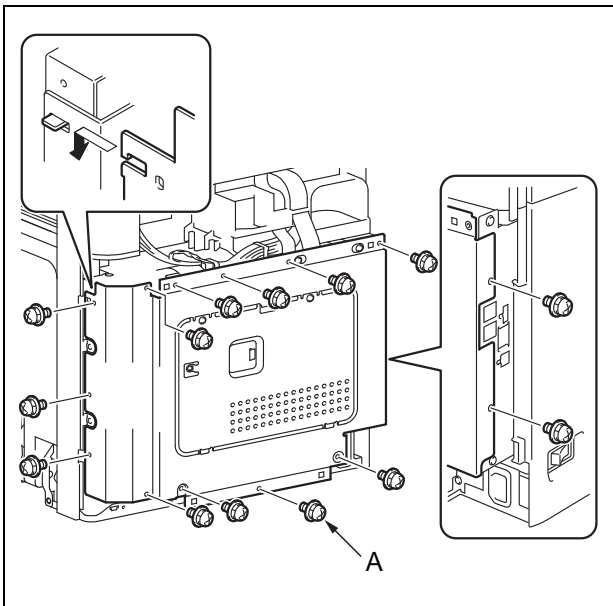

- (20) Reinstall the rear cover. (Six screws)

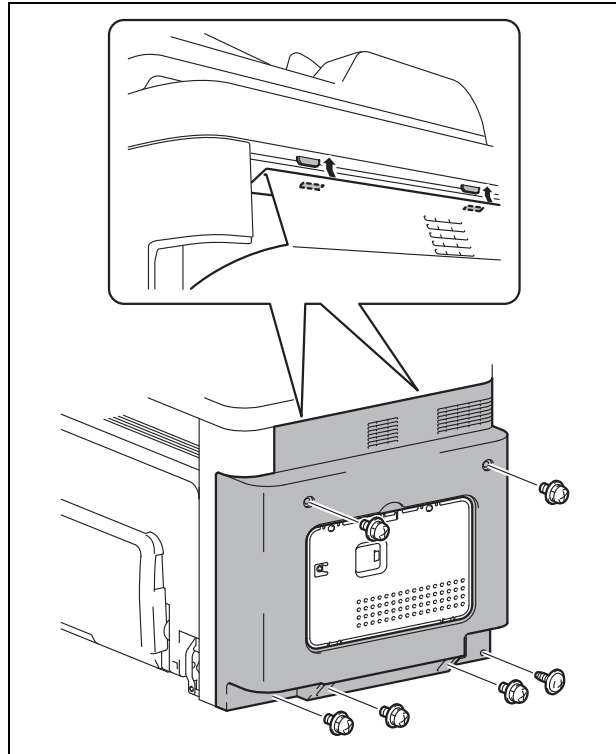

- (21) Reinstall the rear center cover removed in step (3).

- (22) Connect the supplied modular cable to the LINE port.

Note:

If the user is connected with a key telephone system or a private branch exchange (PBX), do not connect the modular cable to where other than an analog line.

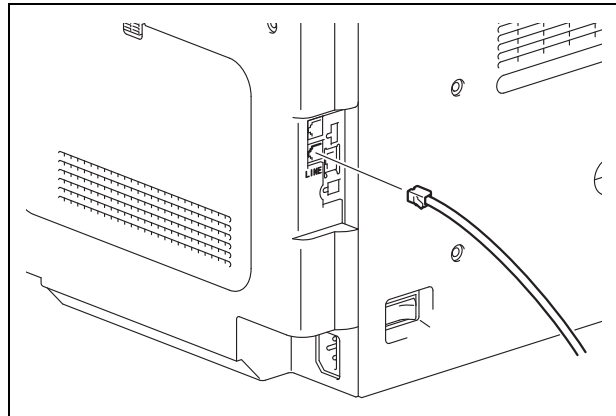

3. Setting the FAX

- (1) Plug the power cord into the power outlet and turn ON the power switch.
- (2) Display the Service Mode screen.
(For details of how to display the Service Mode screen, see the service manual.)
- (3) Select "System 1" → "Fax Target."
- (4) Select the fax target from the ▲ or ▼ key.

Note:

Select the fax target according to the dial system used in the installation place. For DTMF, select "EU", and for dial pulse, select each region name.

- (5) Press the Back key.

4. Initializing the FAX

- (1) Select "Fax Settings" → "Initialization" → "Fax Func Parameter."
- (2) Select "ON."
- (3) Select "Comm Journal Data."
- (4) Select "ON."
- (5) Continue to press Stop/Reset key until the initial screen appears.
- (6) Turn OFF and ON the power switch.

Note:

When displayed the Service Mode screen, be sure to turn off the main power after exiting the Service Mode screen and wait for 10 seconds or more before turning on.

- (7) Perform the sending and receiving tests between the Machine and either the store which offers the service or the local retailer, to check that it can be operated normally.

5. Notes when performing dial transfer

After setting the fax target, dialing operations may be selected after the switchboard dial tone is detected depending on the destination. In this case, depending on the switchboard connected to the machine and the type of dial tone received from the switchboard, dialing operations may not be available. If that happens, you may be able to avoid the problem with the following setting.

<Turn the Dial Tone Detection function OFF>

- (1) Display the Service Mode screen.
(For details of how to display the Service Mode screen, see the service manual.)
- (2) Select "Fax Settings" → "Network" → "DialTone Detection."
- (3) Select "OFF."
- (4) Continue to press Stop/Reset key until the initial screen appears.
- (5) Turn OFF and ON the power switch.

Note:

When displayed the Service Mode screen, be sure to turn off the main power after exiting the Service Mode screen and wait for 10 seconds or more before turning on.

6. Affixing the labels

- (1) Affix the supplied name plate label to the position shown below.

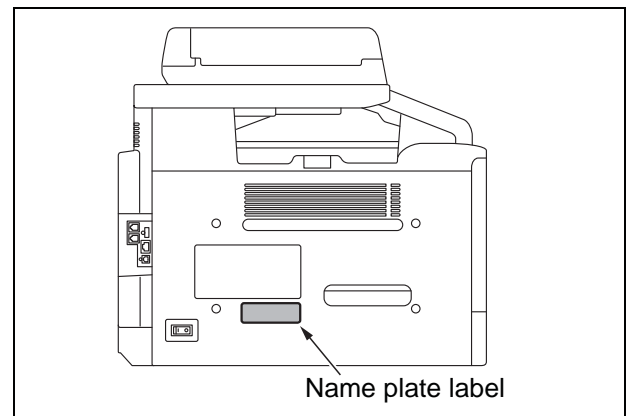

- (2) Affix the supplied super G3 label to the position shown below.

